



UNIVERSITY COLLEGE TATI (UC TATI)

FINAL EXAMINATION QUESTION BOOKLET

COURSE CODE	: DTM 2023
COURSE	: SOLID MECHANICS
SEMESTER/SESSION	: 2- 2024/2025
DURATION	: 3 HOURS

Instructions:

1. This booklet contains **4** questions. Answer **ALL** questions.
2. All answers should be written in answer booklet.
3. Write and Sketch legibly wherever required.
4. Question booklet need to be returned after session ends.
5. If in doubt, raise your hand and ask the invigilator.

DO NOT OPEN THIS BOOKLET UNTIL YOU ARE TOLD TO DO SO

THIS BOOKLET CONTAINS 5 PRINTED PAGES INCLUDING COVER PAGE

QUESTION 1

- a) A round aluminum bar of 2500 mm long and 120 mm diameter elongated by 28 mm under the effect of axial pull of 1500 kN. **Compute:**
- Stress (3 marks)
 - Strain and (3 marks)
 - Modulus of Elasticity (5 marks)
 - the factor of safety if the ultimate strength of 150 MPa (3 marks)
- b) **Compute** the force required to punch a 30 mm-diameter hole in a plate that is 25 mm thick. The shear strength is 350 MN/m². (6 marks)

QUESTION 2

According to Figure 1, the beam is loaded with load at point C and D. The beam can afford the maximum stress of 150 MPa. You need to provide the following information:

- Sketch** the free body diagram (2 marks)
- Compute** the reaction values at both supports. (3 marks)
- Construct** the shear force diagram for the beam. (6 marks)
- Construct** the bending moment diagram for the beam (15 marks)
- Compute** the maximum bending moment for the beam (4 marks)
- Compute** the minimum length of the rectangular cross section of the beam if the width is 50mm (5 marks)

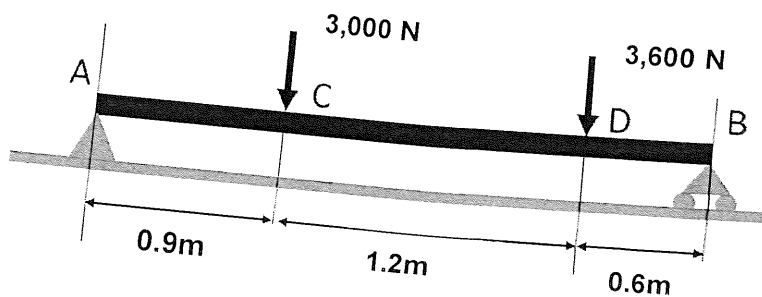

Cross section of the beam

Length(mm)

50mm

Figure 1

QUESTION 3

Figure 2 shows a shaft made up of three segments: Bronze (AB), Aluminum (BC), and Steel (CD). The shaft is fixed to rigid supports and is loaded as shown in the figure. The shaft's diameter is 50 mm. The shear modulus (G) for each material is as follows: Bronze, $G = 35 \text{ GPa}$; Aluminum, $G = 28 \text{ GPa}$; and Steel, $G = 83 \text{ GPa}$

- i. **Draw** the torque graph of the shaft (3 marks)
- ii. **Compute** The maximum shear stress in shaft AB. (3 marks)
- iii. **Compute** The maximum shear stress in shaft BC. (3 marks)
- iv. **Compute** The maximum shear stress in shaft CD. (3 marks)
- v. **Compute** the angle of twist of shaft AB. (3 marks)
- vi. **Compute** the angle of twist of shaft BC. (3 marks)
- vii. **Compute** the angle of twist of shaft CD. (3 marks)
- viii. **Compute** total angle of twist at end A. (4 marks)

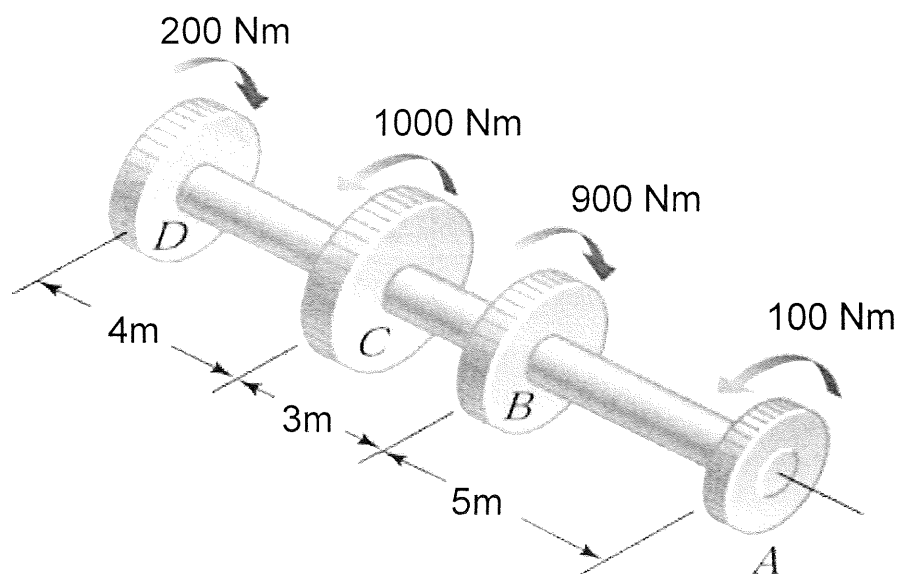

Figure 2

QUESTION 4

Compute the moment of inertia of the I-beam about its horizontal centerline using the parallel-axis theorem. The I-beam, shown in Figure 3, has a bottom flange that is 300 mm wide and 60 mm thick, a web that is 60 mm wide and 300 mm tall, and a top flange that is 150 mm wide and 60 mm thick. Use the given table and formula to help with the calculation. (20 marks)

Block	Area(A)	\bar{y}	Ay	Ixx	d	Ad ²

New Centroid, $\bar{Y} = \frac{\sum \bar{y}A}{\sum A}$	Parellel theorem, $I_{xx(new)} = I_{xx} + Ad^2$
--	---

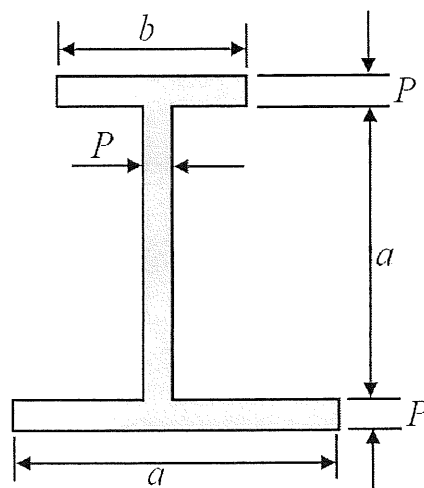

Data : a= 300mm P= 60mm b = 150mm
--

Figure 3

-----end of questions-----

FORMULA

Stress Strain

Normal stress

$$\sigma = \frac{F}{A}$$

Shear stress

$$\tau = \frac{F}{A}$$

Factor of Safety

$$FS = \frac{\sigma_{Ultimate}}{\sigma_{Allowable}}$$

Modulus of Elasticity

$$E = \frac{FL}{Ax}$$

Torsion

General Formula

$$\frac{T}{J} = \frac{G\theta}{L} = \frac{\tau}{R}$$

Polar second moment of area

$$J_{solid\ shaft} = \frac{\pi D^4}{32} \quad J_{hollow\ shaft} = \frac{\pi}{32} (D^4 - d^4)$$

Shear force and Bending Moment

Second moment of Area (Rectangular) = $I_{xx} = \frac{bh^3}{12}$

Minimum Section Modulus, $S_{min} = \frac{\{M\}_{max}}{\sigma_{Allowable}}$

Section Modulus (Rectangular) = $\frac{1}{6}bh^2$

Bending Stress

Parallel Theorem = $I_{SS} = I_{xx} + Ad^2$

